

Mathématiques SANS Frontières



2019

Even partial solutions and attempts can get marks.
Neat and careful work is important.
Hand in only one team answer sheet for each question.

Question 1: Billet gagnant

7 marks

Give your answer in French, German, Spanish or Italian using a minimum of 30 words.

Trois boîtes opaques A, B et C sont côte à côte.

On sait qu'une boîte contient 2 billets de 10 € ; une deuxième boîte 2 billets de 20 € et la troisième boîte 1 billet de 10 € et 1 billet de 20 €.

Devant chaque boîte était posée une étiquette indiquant le montant contenu dans la boîte.

Un petit chenapan a mélangé les étiquettes. Maintenant aucune étiquette ne correspond au contenu.

Expliquer comment, en ne tirant qu'un billet dans une boîte bien choisie, on peut en déduire le contenu de chaque boîte.

Drei nicht durchsichtige Schachteln A, B und C stehen nebeneinander.

Man weiß, dass in einer Schachtel zwei 10€ - Scheine liegen, in einer zwei 20€ - Scheine und in einer ein 10€ - und ein 20€ - Schein.

Vor jeder Schachtel stand ein Schild mit dem Geldbetrag, den sie enthält.

Aber ein kleiner Schelm hat die Schilder vertauscht. Jetzt passt kein Schild mehr zum Inhalt der Schachtel, vor der es steht.

Erklärt, wie man den Inhalt aller drei Schachteln herausfinden kann, indem man nur einen Geldschein aus nur einer gut gewählten Schachtel herauszieht.

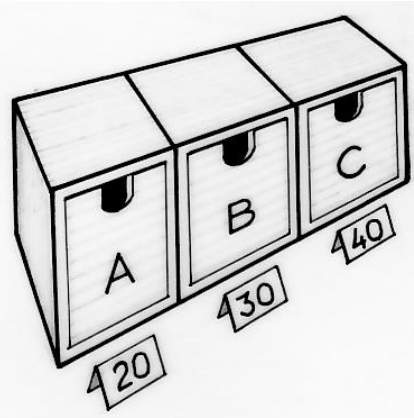

Ci sono tre scatole non trasparenti accostate: A, B e C.

Si sa che una scatola contiene 2 banconote da 10 €; una seconda, 2 banconote da 20 € e la terza, una banconota da 10 € e una da 20 €.

Davanti a ogni scatola c'è un'etichetta con indicato il contenuto in euro della scatola.

Un monello scambia le etichette.

Di conseguenza, nessuna scatola ha davanti l'etichetta corrispondente al suo contenuto.

Spiegare come, estraendo una sola banconota da una scatola scelta oculatamente, si possa dedurre il contenuto di ciascuna scatola.

Tres cajas opacas, A, B y C están una junta a la otra.

Sabemos que una caja contiene 2 billetes de 10 €; una segunda caja 2 billetes de 20 € y la tercera caja 1 billete de 10 € y un billete de 20 €.

Delante de cada caja había una etiqueta con el importe de la caja.

Un niño travieso ha mezclado todas las etiquetas. Ahora ninguna etiqueta se corresponde con el contenido.

Explica cómo, sacando un solo billete de una caja bien elegida, se puede deducir el contenido de cada caja.

Question 2: Happy anniversary

5 marks

At the 30th anniversary celebration of the MSF group, the organisers want to avoid collecting empty cans. To do this, they make a deal where a free can of juice is received for every 5 empty cans returned. The price of a single can of juice is €2.

During the celebration, a group of friends consumes 63 cans of juice. They returned all their empty cans as they went along.

Calculate how much the group of friends spent on drinks during the party.

Under the same conditions, another group of friends spent €200 on juice.

How many cans of juice did they consume? Justify your answer.



Question 3: See me rollin'

7 marks

A box has the shape of a prism whose face is a regular pentagon. The box is “rolled” on a flat surface as follows: turn about the edge AA' until the edge BB' touches the surface, then turn about the edge BB' , and so on.

Draw the pentagon $ABCDE$ with an edge of 4cm.

Draw the line segment EA .

Draw the path of the point B as it is turned, until the point A lies once again on the line segment.

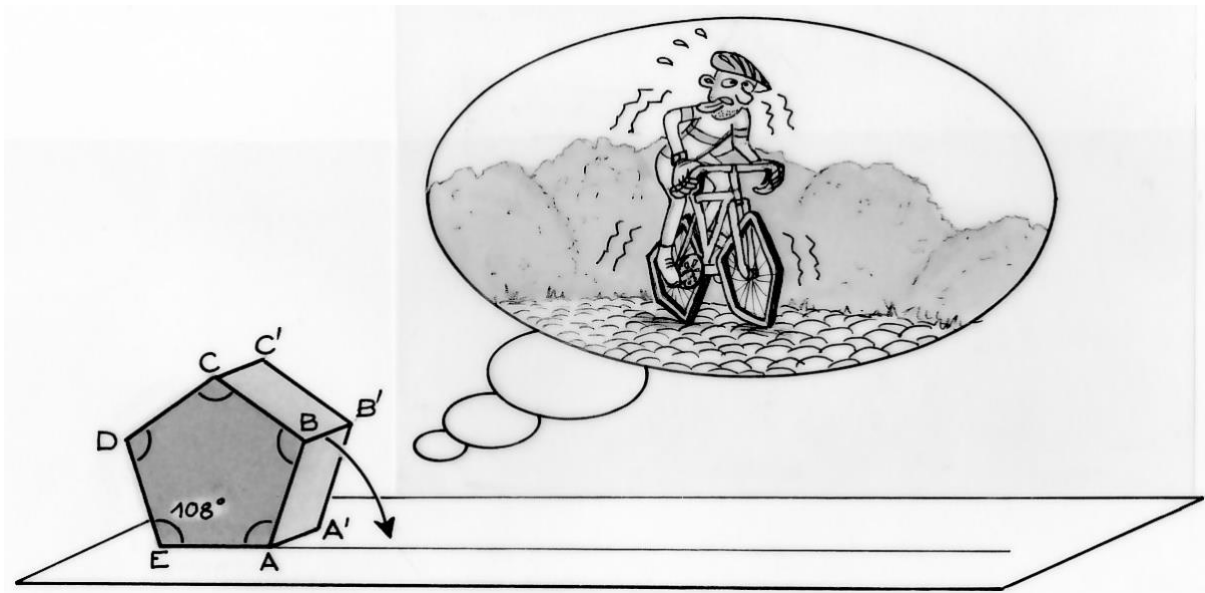

Question 4 : Layer of cubes

5 marks

Samuel is playing with identical wooden cubes. He piles them up to form a cuboid with no interior spaces. He then takes off the 91 cubes which form the upper layer, followed by 77 cubes which make up one of the side faces. Finally, he removes all the cubes which form the rear face.

Determine the number of cubes left.



Question 5: Organic tomatoes

7 marks

Jacqueline farms organic crops. To treat her vegetables, she prepares an extract of nettles in one container and, in another container, an extract of horsetail.

To treat her tomatoes, she requires a mixture of 5L of the nettle extract and 1L of the horsetail extract, to give 6L of the required substance. Only two empty cans are available to do this – a 3L can and a 10L can.

Explain how Jacqueline can use the empty cans to create the 6L mixture she needs.



Question 6: After eights

5 marks

I distributed 100 sweets into 5 boxes.

The number of sweets in each box contains the digit 8. Only two boxes have the same number of sweets.

How many sweets are in each box?



Question 7: In a queue

7 marks

If we write the positive whole numbers in ascending order, without leaving any number out, we obtain 012345678910111213141516...

To determine the position of a number, count how many digits have been written before that number appears for the first time in the list.

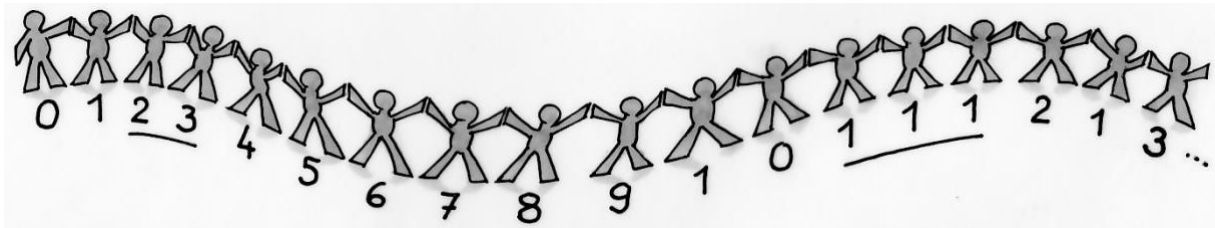

For example, the position of 7 is 7; the position of **23** is 2 and the position of **111** is 12.

Determine the position of the following numbers: 171, 321 and 2019.

Question 8: Pass tent

5 marks

In a mathematical article published in 1492 titled “Lo Compendion del Abaco”, Elise found an engraving representing a tent. The tent is in the shape of a conic called a “tref”, and is supported in the centre by a mast. The tent is intended to shelter the lord.

From the engraving, Elise understands that 40 represents the height of the shaft around which the canvas is hanging, 50 is the length from the top of the mast to the ground when the canvas is stretched. She knows that $188 \frac{4}{7}$ means $188 + \frac{4}{7}$.

Explain what $188 \frac{4}{7}$ means.

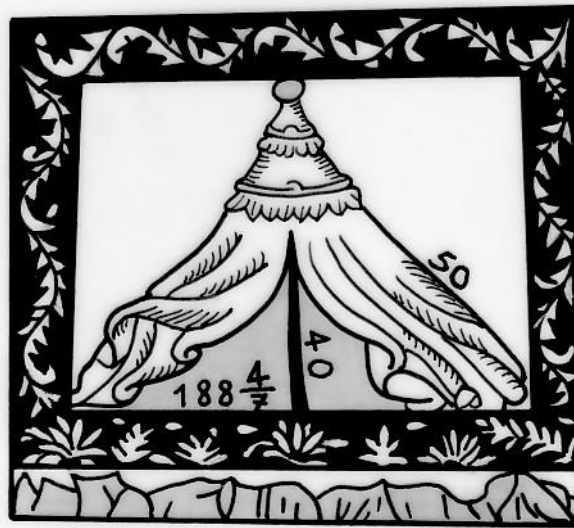

Question 9: Quadratum

7 marks

Gallo-Romans made square tile patterns. To create a square with sides measuring 70cm, they used 5 kinds of pieces namely:

- 4 squares each with side measuring 25cm;
- 4 triangles (not isosceles) each with a hypotenuse measuring 25cm;
- 2 isosceles triangles with the equal sides each of length 25cm;
- 2 more isosceles triangles with the equal sides each of length 25cm;
- 1 rhombus (not square) with each side of length 25cm.

Using a scale of 1:5 draw a square showing how these 13 pieces could be put together.

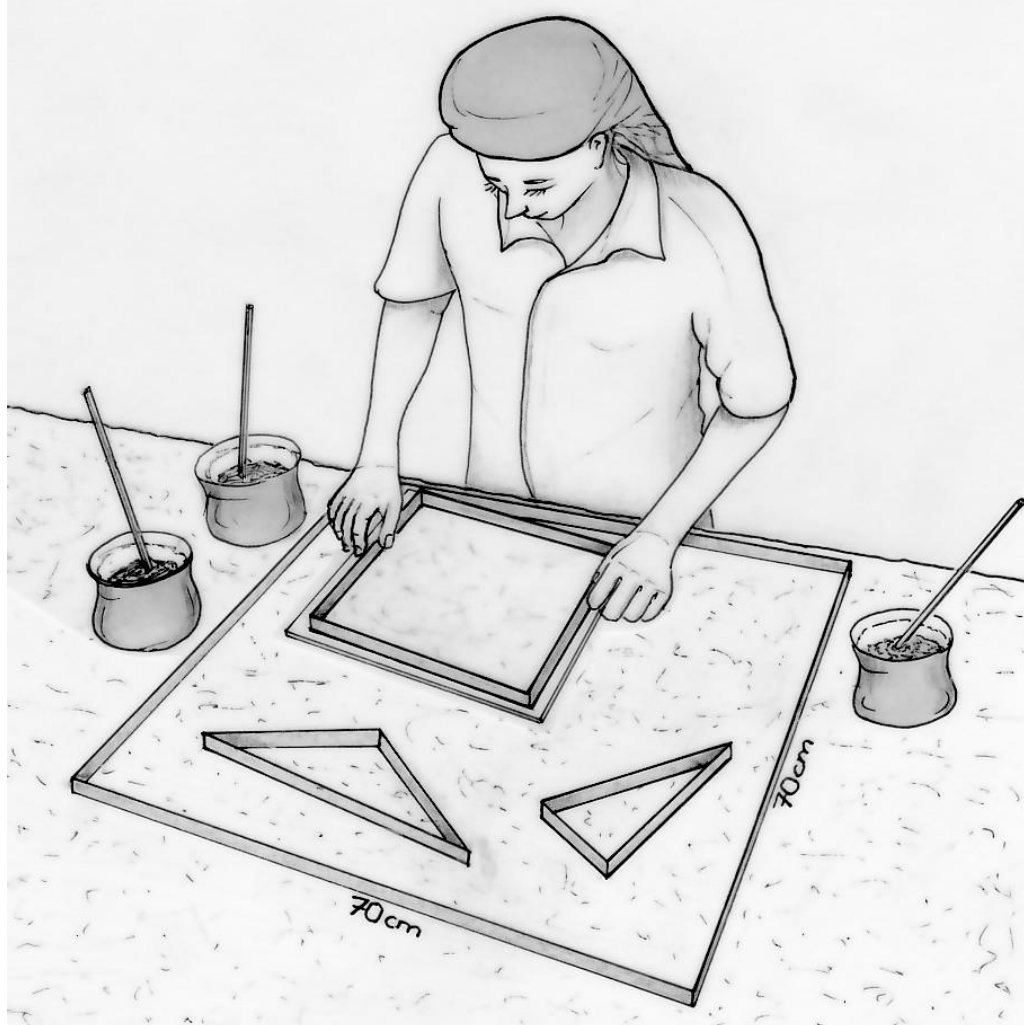

Colour your square appropriately.

Question 10: Tetra-ordinary

10 marks

Here's how you can obtain a tetrahedron from the net of a cube. From the picture:

- Draw this net of a cube with sides of 5cm;
- Draw the dotted line segments as shown;
- Cut out this net;
- Fold along the dotted line segments;
- Arrange the folds to make a tetrahedron.

Paste the net of the cube on your answer sheet, colouring each face of the tetrahedron with the same colour.

Calculate the area of each face of the tetrahedron.

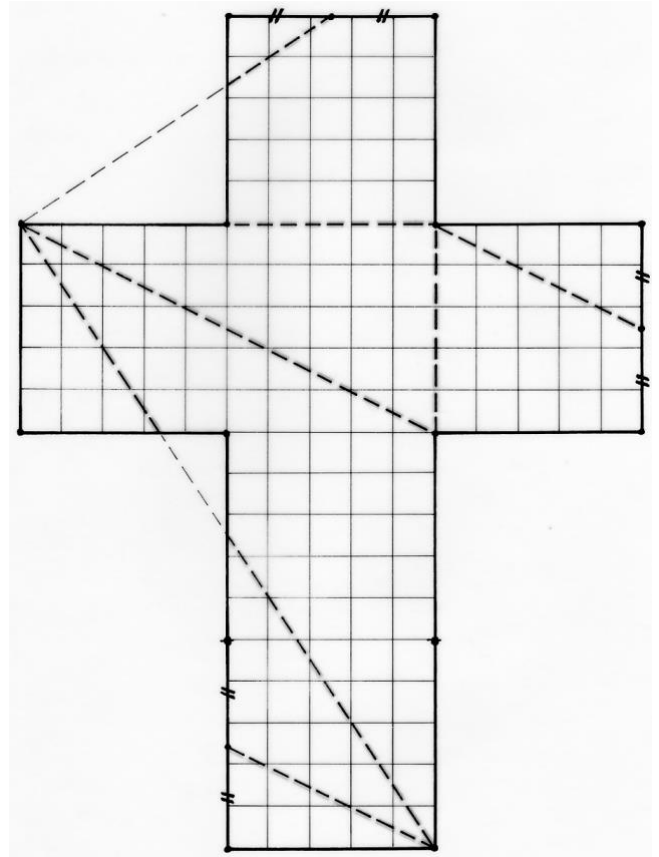

Senior classes only

Question 11: Step up

5 marks

When observing people using an escalator, some climb steps to gain time.

Jean, who climbs 20 steps, takes 10 seconds to arrive at the top.

Delphine, who climbs 16 steps, takes 12 seconds to arrive at the top.

How many visible steps does this escalator have? Justify your answer.



Senior classes only

Question 12: Wat-a-story

7 marks

Noah's aquarium is a rectangular parallelepiped with dimensions of 50cm by 25cm by 40cm.

Noah wants to fill the aquarium with tap water but the location of the tap forces him to incline the aquarium at an angle of 45° . Water flows in up until the edge of the aquarium.

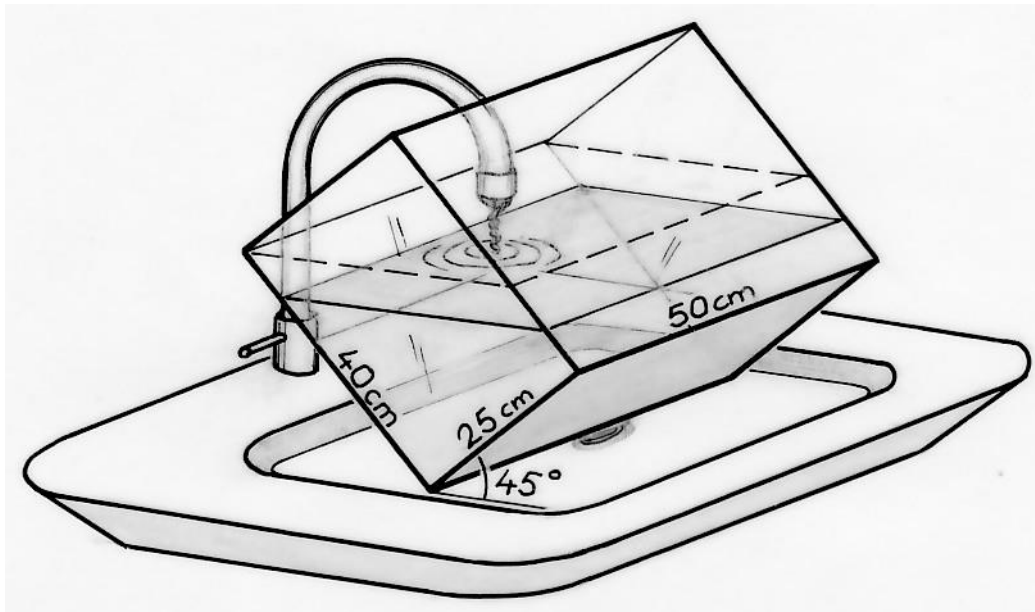

Calculate the maximum height of the water in the aquarium.

Question 13: Quadrilat-area

10 marks

A quadrilateral ABCD is split into 4 parts by two line segments joining the points E, F, G and H which are the midpoints of its sides as shown.

The area of quadrilateral IHAE is 165cm^2 ; the area of quadrilateral IEBF is 115cm^2 , and the area of quadrilateral IFCG is 175cm^2 .

What is the area of quadrilateral IGDH? Justify your answer.

